

Efficiency Enhancement

State of the Art Technology & Combustion Optimization Techniques*

CFD Methods used to develop Air-Fuel Ratios

Using CFD to predict Air-Fuel Mixture

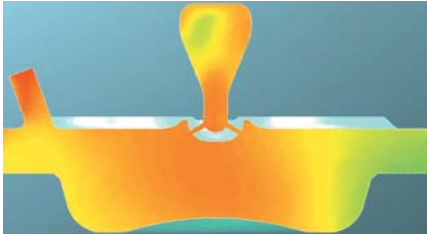

Used in developing design basis and Test Plan Process

Air-Fuel Mixture Analysis using FFD

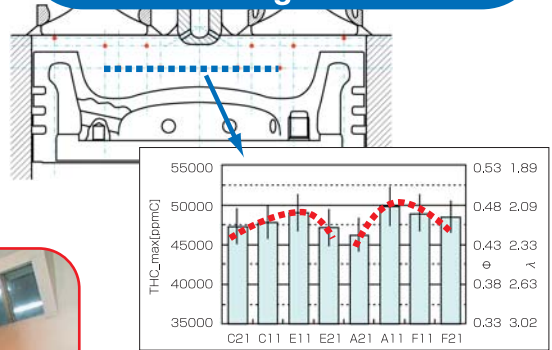

Measuring of air-fuel mixture formation



Model Evaluation through Real World Test Engine Trials

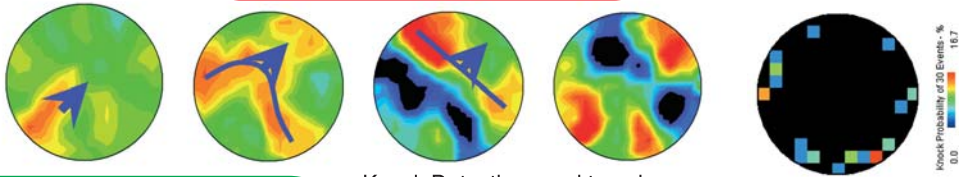

Knocking Intensity Visualization using CT Method

Knock Detection used to enhance Flame Propagation and Improve Combustion

* In developing this technology, we applied results gained from "Development of Technology for Ultra High-efficiency Natural Gas Engine Combined System" a joint development project under way since 2005 together with the New Energy and Industrial Technology Development Organization (NEDO) and the Japan Gas Association.

Comparison between spark ignition (GSI) and micro pilot injection (GA).

KU30GSI combustion system

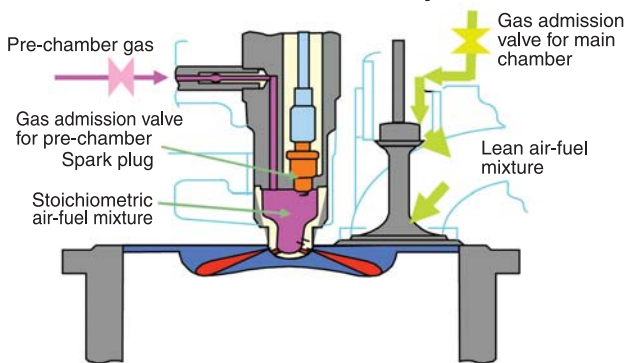

KU30GA combustion system

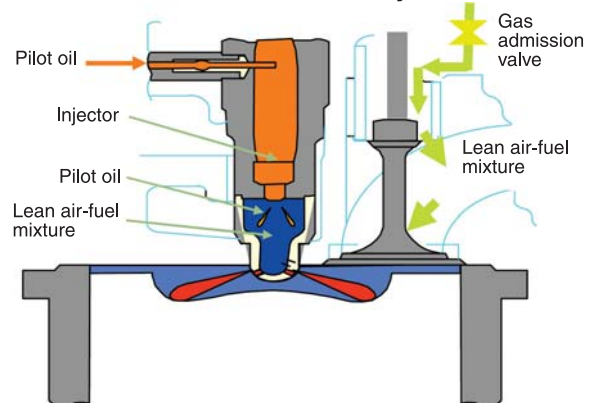

Based on KU30G(*1), the technology of KU30GA is applied, so high power is achieved.

Feature

- High efficiency and high exhaust gas temperature by optimizing combustion
- Long life time of spark plug = 2,000 Hours
- Shorter start time compared with KU30GA

*1: Spark Ignition gas engine developed in 1990

Feature

- Strong ignition energy by pilot oil compared with spark plug
- Various composition of fuel gas can be applied
- Long continuous running time by injector compared with spark plug
- Low NOx emission by lean air-fuel mixture in pre-chamber

Mitsubishi's Combustion Control Technology:

M-RICS Mitsubishi Real-time Intelligent Control System

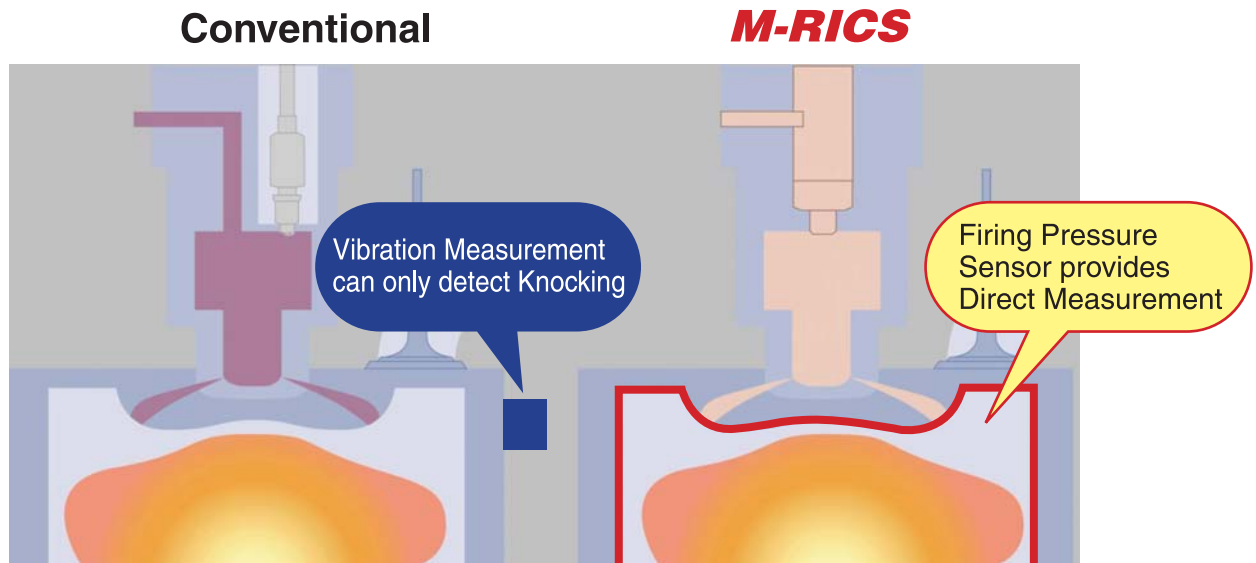

What is **M-RICS**?

The real time application of instrumentation & control technologies to detect individual cylinder firing pressure and provide feedback control to optimize the combustion process.

Mitsubishi was the first to pioneer this approach and successfully implement the solution in production equipment with the KU30GA and KU30GSI engines. Many conventional engines can only detect engine knocking using vibration sensors and lack the control, however these features has been enabled by M-RICs.

Advantages of **M-RICS**

1. Equalized firing pressures in all cylinders
→ **High Efficiency**
2. Optimizes firing pressures despite variations in fuel heating value, engine component aging, ambient condition changes, etc.
→ **Stabilized & Predictable Performance**
3. Immediate detection of abnormal conditions, allowing rapid adjustment in load and/or fuel supply
→ **Enables Abnormal Combustion Ride-Thru**
→ **Stabilized & Predictable Performance**
4. Continuous Data Stream available for Storage:
→ **Supports prognostic maintenance and component life forecasts and predictions**

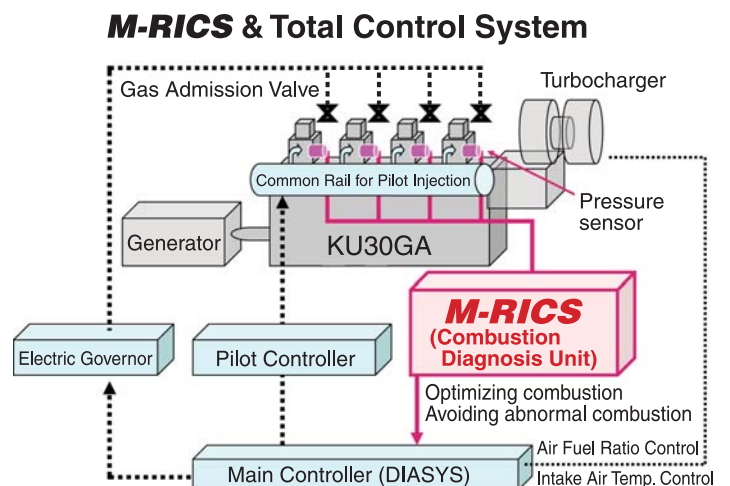

MITSUBISHI HEAVY INDUSTRIES, LTD.

Head Office

16-5, Konan 2-chome, Minato-ku, Tokyo, Japan
Phone: 81-3-6716-4489
Telefax: 81-3-6716-5772

Yokohama Dockyard & Machinery Works

Kanazawa Plant
8-1, Sachiura 1-chome, Kanazawa-ku, Yokohama, Japan
Phone: 81-45-775-1202
Telefax: 81-45-775-1242